

MASTER DIRECT OIL HEATERS

MODEL 100 CED 29 kW

PARTS LIST

Key No.	Part Number	Description	Qty.	Key No.	Part Number	Description	Qty.
1	4104.006	Upper Shell	1	16	4103.850	Edge Liner	1
2	4109.590	Screw/Lockwasher, 1/2"	8	17	4110.186	Motor Bracket	1
3	4101.180	Combustion Chamber	1	18	4160.613	Lock Washer, #10	2
4	4100.658	Photocell Bracket	1	19	4110.134	Nut, #10-32	3
5	4110.564	Photocell Assembly	1	20	4108.486	Hex locknut	2
6	4100.632	Drain Plug	1	21	4110.609	Electronic Ignitor	1
7	4103.529	Screw, #6-32 x 3/8"	2	22	4108.510	Screw, #10-16 x 3/4"	2
8	**	Burner Head Assembly	1	23	4106.110	Terminal Board	1
8-1	4103.559	Nozzle	1	24	4110.571	Rivet	1
8-2	4100.525	Nozzle Seal Washer	2	25	4101.112	Bushing	1
8-3	4100.533	Nozzle Seal Spring	1	26	4101.112	Bushing	1
8-4	4101.622	Nozzle Seal Sleeve	1	27	4160.646	Bushing	2
8-5	4109.352	Burner Head Body	1	28	4110.070	Button Plug	1
8-6	4104.118	Barb Fitting	2	29	4105.287	Power Line RFI Filter	1
8-7	4101.846	Spark Plug	1	30	4110.566	Lower Shell	1
9	4110.124	Screw/Lockwasher, 1/2"	13	31	4104.170	Clip Nut	8
10	4104.147	Air Line	1	32	4110.133	Screw, #10-32 x 3/4"	1
11	4110.032	Fuel Line	1	33	4100.630	Fuel filter	1
12	4105.062	Fan	1	34	4100.541	Rubber Bushing	1
13	**	Motor and Pump Assembly	1	35	4110.147	Fuel Line	1
13-1	4110.080	Motor with capacitor	1	36	4110.149	Fuel Tank	1
13-2	4101.317	Pump Body	1	37	4103.891	Fuel Tank Cap	1
13-3	4108.588	Screw, #10-32 x 5/8"	2	38	4110.195	Wire Assembly (red) 1	1
13-4	4108.635	Insert	1	39	4104.196	Flame-Out Control	1
13-5	4108.627	Rotor	1	40	4150.528	Strain Relief Bushing	1
13-6	4101.325	End Pump Cover	1	41	4110.563	Power Cord	1
13-7	4101.358	Intake Filter	1	42	4110.062	Side Cover	1
13-8	4108.643	End Cover	1	43	4109.592	Hex Nut	1
13-9	4108.379	Steel Ball (1/4" Dia.)	1	44	4104.336	Switch Cover	1
13-10	4102.141	Pressure Relief Spring	1	45	4110.164	Wire Assembly (black)	2
13-11	4102.133	Adjusting Screw	1	46	4106.179	ON/OFF Switch	1
13-12	4102.125	Plug	1	PARTS AVAILABLE - NOT SHOWN			
13-13	4108.528	Screw, #10-32 x 1"	4	4105.292	Filler Neck Screen	1	
13-14	4101.341	Output Filter	1				
13-15	4108.528	Screw, #10-32 x 1"	6				
13-16	4101.333	Lint Filter	1				
13-17	4104.118	Barb Fitting	1				
13-18	4101.200	Blade	4				
14	4103.695	Fan Guard	1				
15	4150.553	Rubber Bumper	2				

** Parts not available as an assembly, order parts separately.

WHEELS AND HANDLES

100,000 AND 150,000 BTU/HR MODELS

KEY NO.	PART NUMBER	PART DESCRIPTION	100,000 QTY.	150,000 QTY.
1	HA2203	Handles	2	---
	HA2204	Handles	---	2
2	M12345-33	Screw, #10-24 x 1 3/4"	8	8
3	M12342-3	Wheel Support Frame	1	---
	M12831-3	Wheel Support Frame	---	1
4	NTC-3C	Hex Nut, #10-24	8	8
5	107426-01	Wheel (2)	1	1
6	M28526	Cap Nut	2	2
7	M51015-0	Axle	1	---
	M16801-2	Axle	---	1

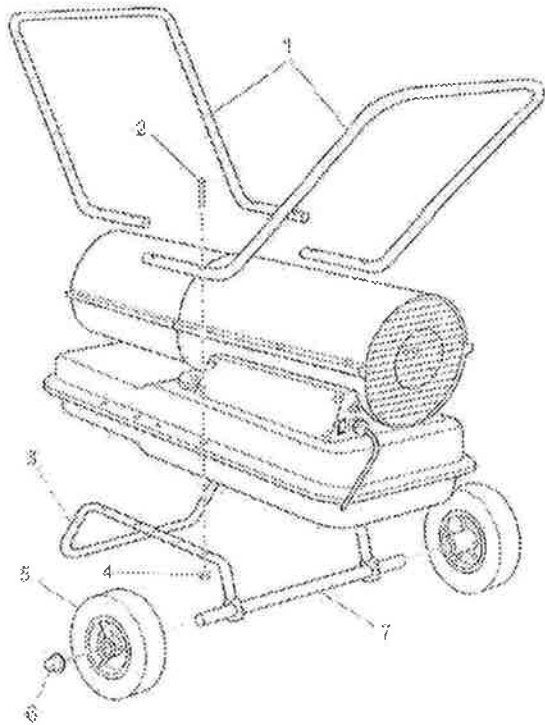

ACCESSORIES

Purchase accessories from your local dealer.



AIR GAUGE KIT - HA1180

For all models. Special tool to check pump pressure.

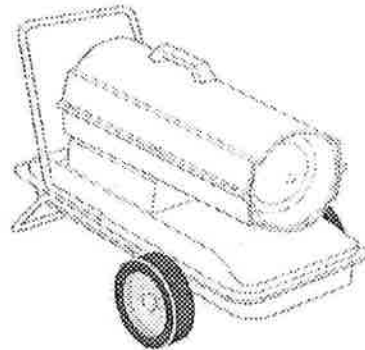
HEAVY DUTY WHEELS AND HANDLE KIT
HA1202

For heavy duty applications. Makes your heater even more portable and convenient. For 35/70,000 Btu/Hr models.

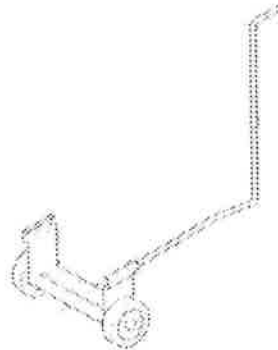
STANDARD WHEELS AND HANDLE KIT
HA1206

Makes heater even more portable and convenient. Easy to assemble. For 35/70,000 Btu/Hr models.